

# BRIEF COMMUNICATION

## A TECHNIQUE TO CONSTRUCT A BOILING CURVE FROM QUENCHING DATA CONSIDERING HEAT LOSS

S. C. CHENG, K. T. HENG and W. NG

Department of Mechanical Engineering, University of Ottawa, Ottawa, Canada

(Received 5 September 1976)

### 1. INTRODUCTION

This is a sequel to our earlier work (Cheng & Heng 1976) and it has been developed in connection with our current study on transition boiling heat-transfer in forced vertical flow by quenching (Cheng & Ng 1976). In this paper, some modifications, such as heat loss through the outer wall, have been incorporated with the earlier model (Cheng & Heng 1976) in the construction of the boiling curve. The possibility of axial heat-conduction has also been discussed. Heat flux is calculated by solving the Fourier transient equation and using the concept of rate of changing heat content within the test section (Cheng *et al.* 1974). The Continuous System Modeling Program (CSMP) (IBM Manual 1972) has been used in obtaining the numerical solution.

### 2. ANALYSIS-*h* METHOD

The experimental test section consists of a 5.72 cm long cylindrical copper block with 9.53 cm outside diameter and a center bore of 1.27 cm to allow the fluid to pass through. The outer wall of the copper block is insulated. Cartridge heaters are spaced around the copper block and a total of five thermocouples are embedded, two of them close to the inner wall surface as shown in figure 1. The assembly drawing for test section No. 1 is shown in figure 2, where the experimental apparatus and procedure are described elsewhere (Cheng & Ng 1976). Heat transfer from the test section to the fluid between time 0 and *t* is assumed equal to the change in heat content *Q* inside the cylinder, minus heat loss through the outer wall during the same time interval. *Q* can be expressed as

$$Q(t) = \rho c_p L \int_{r_{in}}^{r_{out}} 2\pi r T dr \quad [1]$$

where *L* represents the length of the test section. The function *T*(*r*, *t*) is obtained as the

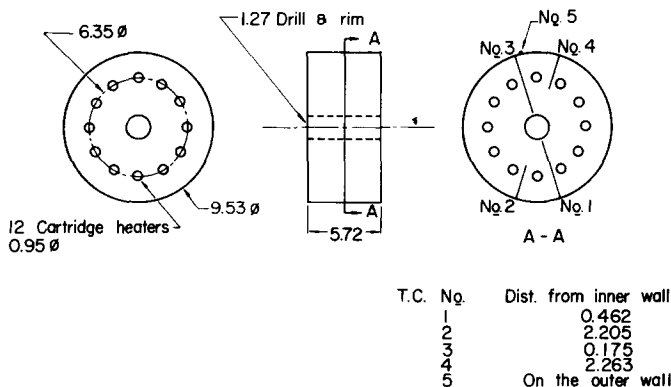

Figure 1. Test section design No. 1.

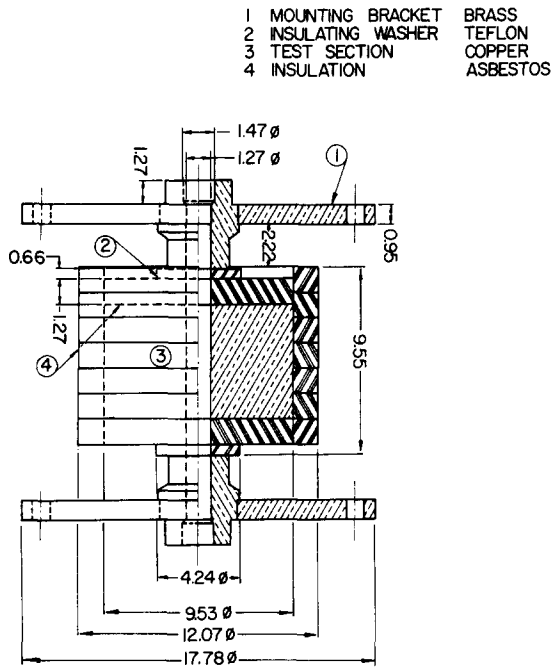

Figure 2. Assembly drawing for test section No. 1.

solution to the one-dimensional Fourier equation in cylindrical coordinates:

$$\frac{\partial T}{\partial t} = \alpha \left( \frac{\partial^2 T}{\partial r^2} + \frac{1}{r} \frac{\partial T}{\partial r} \right) \quad [2]$$

and is subject to the following initial and boundary conditions:

- (1)  $T = T(r, 0) \dots$  In general, at  $t = 0$  the temperature across the test section is linear with about  $4^\circ\text{C}$  difference for our initial temperature condition. [3]
- (2)  $T(r_0, t) = T_0 \dots$   $r_0$  and  $T_0$  are the location and recordings of thermocouple No. 3, respectively. [4]
- (3)  $-k(\partial T/\partial r)_{r=r_{out}} = h(T_n - T_{amb}) \dots$   $h$  is the heat-transfer coefficient at the outer wall and its determination will be explained later. [5]

The solution of [2] can be obtained by reducing it to a system of linear first-order differential equations in  $t$ . This is achieved by discretizing along the  $r$ -direction (figure 3) using the

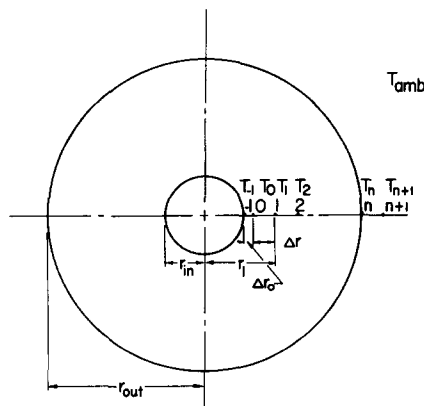

Figure 3. Nodal points distribution.

approximation

$$\frac{\partial T}{\partial r} = \frac{T_{i+1}(t) - T_{i-1}(t)}{2\Delta r} \quad [6]$$

and

$$\frac{\partial^2 T}{\partial r^2} = \frac{T_{i-1}(t) - 2T_i(t) + T_{i+1}(t)}{(\Delta r)^2} \quad [7]$$

where  $T_i(t)$  represents the temperature at the  $i$ th nodal point ( $1 \leq i \leq n+1$ ) and  $\Delta r = [r_{out} - (r_{in} + \Delta r_0)]/n$ .

Using [6] and [7] along with initial and boundary conditions, the following system of equations can be inferred from [2].

$$\frac{dT_i}{dt} = \alpha \left[ \frac{T_{i-1} - 2T_i + T_{i+1}}{(\Delta r)^2} \right] + \frac{\alpha}{r_i} \left( \frac{T_{i+1} - T_{i-1}}{2\Delta r} \right) \quad [8]$$

$1 \leq i \leq n$

where

$$r_i = r_{in} + \Delta r_0 + i\Delta r$$

and

$$-\frac{k}{2} \left( \frac{T_i - T_{i-1}}{\Delta r} + \frac{T_{i+1} - T_i}{\Delta r} \right) = h(T_i - T_{amb}) \quad i = n \quad [9]$$

[9] is a direct consequence of [5]. Furthermore,  $T_{n+1}$  in [8] can be eliminated by using [9].

Equation [8] contains a system of  $n$  equations with  $n$  unknowns in  $T_i$  and are readily to be solved. Once  $T_1$  up to  $T_n$  have been solved and  $dT_0/dt$  determined experimentally, the inner wall temperature  $T_{-1}$  can then be calculated in the following Fourier equation based on the nodal point  $i = 0$

$$\frac{dT_0}{dt} = \left( \left[ \frac{(T_1 - T_0)/\Delta r - (T_0 - T_{-1})/\Delta r_0}{(1/2)(\Delta r + \Delta r_0)} \right] + \frac{\alpha}{r_0} \left( \frac{T_1 - T_{-1}}{\Delta r + \Delta r_0} \right) \right) \quad [10]$$

Equation [1], expressed in terms of summation, becomes

$$Q = 2\pi\rho c_p L \left[ 0.5T_{-1}r_{in}\Delta r_0 + 0.5T_0(r_{in} + \Delta r_0)\Delta r_0 + 0.5T_0(r_{in} + \Delta r_0)\Delta r + \left( \sum_{j=1}^{n-1} T_j r_j + 0.5T_n r_n \right) \Delta r \right] \quad [11]$$

The expression of net heat-transfer to the fluid  $q$  in terms of  $Q$  and heat loss is:

$$\begin{aligned} q &= -\frac{dQ}{dt} / A_{in} - hA_{out}(T_n - T_{amb})/A_{in} \\ &= -\frac{1}{2\pi r_{in} L} \frac{dQ}{dt} - \frac{hr_{out}}{r_{in}} (T_n - T_{amb}) \end{aligned} \quad [12]$$

where  $A_{in}$  and  $A_{out}$  represent the inner and the outer test section area, respectively.

## 3. SIMPLIFICATION—TWO-POINT METHOD

If the recordings of thermocouple No. 5 are known in the experiment, then  $T_n$  is known. Equation [8] can be solved directly for nodal points  $1 \leq i \leq n-1$  without involving [9]. Thus yields  $T_1$  up to  $T_{n-1}$ , the determination of  $T_{-1}$  and  $q$  is the same as before.

## 4. RESULTS AND CONCLUSION

All calculations were performed via CSMP computer package. Due to its flexibility, power, relative ease of use and plotting capability, CSMP has gained wide acceptance recently in solving differential equations (Cheng *et al.* 1974). The Runge-Kutta fixed-step size method has been used in numerical integration with selection of  $n = 8$  and  $\Delta t = 0.1$  sec and its convergency checked. NLFGEN function generation (nonlinear function generation) capability of CSMP was used to generate  $T_0$  from experimental data and DERIV (derivative) module used to compute  $dT_0/dt$  from  $T_0$  and  $dQ/dt$  from  $Q$ . A complete program has been established starting with thermocouple No. 3 recordings (mV vs time) as input, and at the end  $q$  vs the wall temperature printed and plotted. The conversion table for millivolts vs temperatures has been built in the program to expedite the conversion.

Figure 4 presents one of the typical results for distilled water with the mean initial temperature for the test section at  $287^\circ\text{C}$  using the perfectly insulated method (Cheng & Heng 1976), the  $h$  method and the two-point method. In general, as one would expect, the perfectly insulated method has slightly overestimated heat-flux compared with the other two methods. Both the  $h$  method and the two-point method yield close results except the former produces somewhat higher values in the nucleate boiling régime and lower values in the transition boiling régime. The heat-transfer coefficient  $h$  at the outer wall has been determined experimentally under a no-flow condition. Its value stays nearly constant at  $34 \text{ W/m}^2\text{C}$  for most of the temperature range operated except at the lower temperature range where it drops to  $22.7 \text{ W/m}^2\text{C}$ . For simplicity, a constant value of  $34 \text{ W/m}^2\text{C}$  has been assumed in the computation. However, a variable expression of  $h$  as a function of temperature can be simply incorporated within CSMP capability by using the function generation.

The proposed method to construct a boiling curve from quenching data is only valid when no axial conduction exists. In reality, there is always some axial conduction occurring, e.g. imperfect insulation at the end of the test section. More severe axial heat-loss could happen due to the possibility of immense nucleate boiling present just outside both ends of the test section and initiate rewetting fronts. These rewetting fronts could then travel back into the test section,

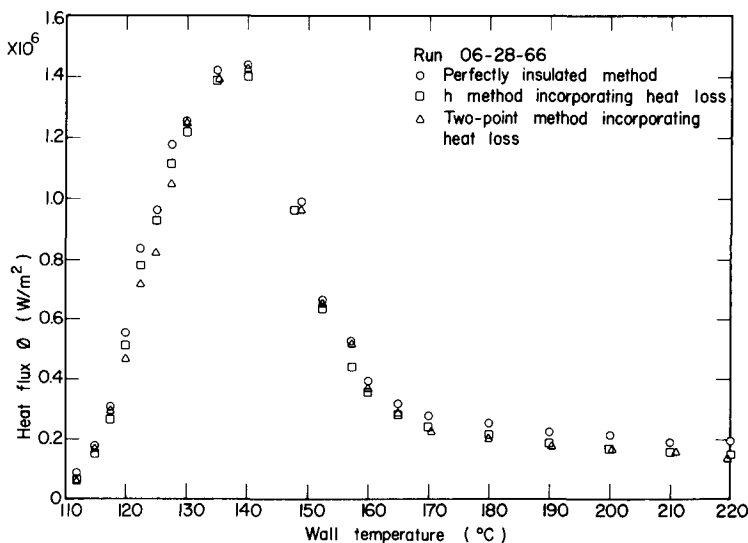

Figure 4. Boiling curves for distilled water for  $G = 136 \text{ kg/m}^2 \text{ sec}$ ,  $\Delta T_{\text{sub}} = 0^\circ\text{C}$  and  $p = 1 \text{ bar}$ .

thus interfering with the spontaneous rewetting phenomenon inside the test section. However, in our experimental set-up, the test section does not contact the bracket and the connecting pipe directly, instead, they are separated by Teflon and asbestos insulators (figure 2). Therefore, it minimizes the axial heat-flow from the test section due to aforementioned nucleate boiling and its subsequent propagation of the rewetting front. This is especially true for flow with low mass flux and small degrees of subcooling. Latest experiments involving thermocouples located at different cross-sectional planes, to check axial conduction, have confirmed this argument.

During the quenching process in our current study, the heaters were shut off. In order to prolong the quenching time, especially the duration of transition boiling time, the heaters could be left on. From the analysis point of view, this requires a modification of the Fourier equation by incorporating the proper heat source term.

An alternative method to calculate  $q$  and the inner wall temperature from experimental data  $T_0$  requires the solution of the so-called inverse heat transfer problem (Iloeje *et al.* 1973). The solution is quite complicated and it involves the determination of up to third order derivatives of  $T_0$ . The proposed technique is much simpler and theoretically sound.

#### REFERENCES

- CHENG, S. C. & HENG, K. T. 1976 A technique to construct a boiling curve from quenching data. *Lett. Heat Mass Transfer* 3, 413–420.
- CHENG, S. C., KULKARNI, K. & BIRTA, L. G. 1974 Insurge transients from a surge tank using a CSMP. *Simulation* 23, 109–114.
- CHENG, S. C. & NG, W. 1976 Transition boiling heat transfer in forced vertical flow via a high thermal capacity heating process. *Lett. Heat Mass Transfer* 3, 333–342.
- IBM System/360 Continuous System Modeling Program User's Manual Program 1972 No. 360 A-CX-16X.
- ILOEJE, O. C., PLUMMER, D. N. & GRIFFITH, P. 1973 An investigation of the collapse and surface rewet in film boiling in forced vertical flow. ASME Paper No. 73-WA/HT-20.